

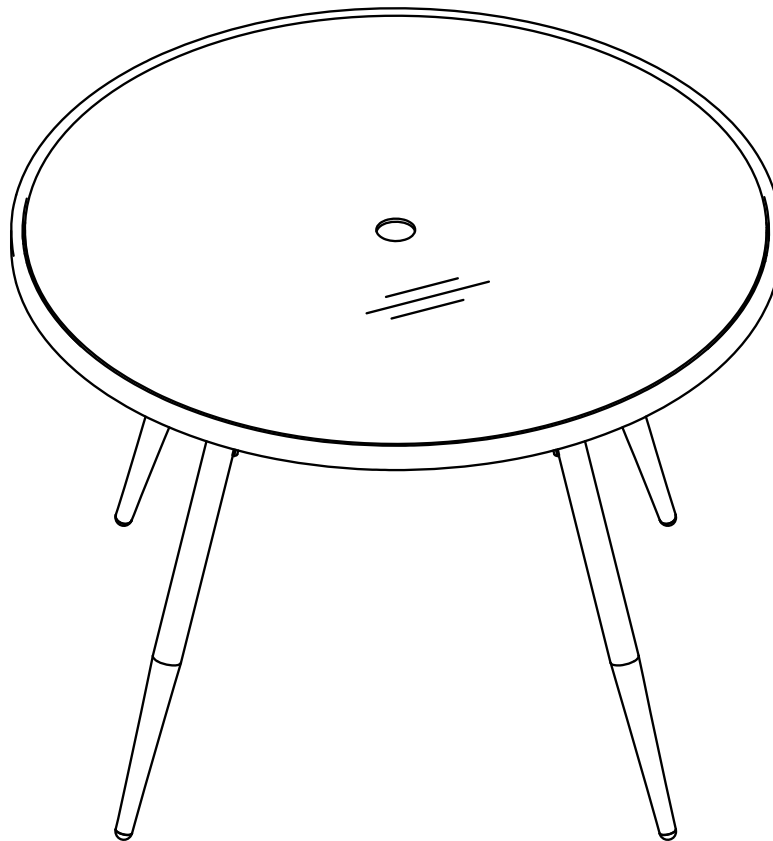

Item #1001074502
Model #FRN-910220

USE AND CARE GUIDE

MARGIE DINING TABLE



Questions, problems, missing parts?
Before returning to the store, call Hampton Bay Customer Service
8 a.m. - 7 p.m., EST, Monday – Friday, 9 a.m. – 6 p.m., EST, Saturday

1-855-HD-HAMPTON

HOMEDEPOT.CA

THANK YOU

We appreciate the trust and confidence you have placed in Hampton Bay through the purchase of this table. We strive to continually create quality products designed to enhance your home. Visit us online to see our full line of products available for your home improvement needs. Thank you for choosing Hampton Bay!

Table of Contents

Safety Information 2
Warranty 2
Care and Cleaning 2
Pre-Assembly 3
 Planning Assembly. 3
 Hardware Included. 3
 Package Contents 3
Assembly. 4-5

Important Safety Instructions

READ ALL INSTRUCTIONS BEFORE USE

To reduce the risk of injury to persons:

1. Close supervision is necessary when this furnishing is used by or near children, or disabled persons, if applicable.
2. Use this furnishing only for its intended use as described in these instructions. Do not use attachments not recommended by the manufacturer.
3. This table is not intended to support an umbrella. Umbrellas must have a suitable base or stand.

 **DANGER:** Keep children out of the assembly area during assembly.

 **WARNING:** Do not sit or stand on the table.

 **CAUTION:** Do not use sharp equipment such as a knife and scissors when removing the protective material, as it may damage the product.

Warranty

2 YEAR LIMITED WARRANTY

WHAT IS COVERED

The frame is warranted to be free of manufacturing defects for two years from the purchase date. If the frame of your furniture fails (ie. broken frame or weld) within two years of ownership, Hampton Bay will repair, provide replacement parts, or replace the product at our option. Frame finishes are warranted against blistering, cracking, or peeling for two years from purchase date. This is a residential use warranty only. Warranty is void when product is used for commercial settings. This warranty is a limited warranty and applies to the original purchase only. Proof of purchase is required.

Contact the Customer Service Team at 1-855-HD-HAMPTON or visit HOMEDEPOT.CA.

Care and Cleaning

- Use mild soap and warm water to clean the frames.
- Rinse with clean water and dry thoroughly.
- Be sure to drain any water accumulated inside the frames. To thoroughly drain frames, remove foot caps and tilt frames, if necessary, to remove all water. Water allowed to accumulate inside the frames and then exposed to sub-freezing temperatures can cause damage to frame tubing. Such damage is not covered under warranty.
- Use commercially available glass cleaners. Do not use abrasive materials, cleansers or bleach products.

Pre-Assembly

PLANNING ASSEMBLY

Before beginning the assembly of this product, make sure all parts are present. Compare parts with Package Contents and Hardware Included lists. If any part is missing or damaged, do not attempt to assemble the product, and return it to the place of purchase.

HARDWARE INCLUDED

 **NOTE:** Hardware not shown to actual size.



Part	Description	Quantity
AA	Washers	20
BB	Bolt (M6x15)	20
CC	Hex Wrench	1
DD	Bolt Cap	20
EE	Umbrella Cap	1

PACKAGE CONTENTS

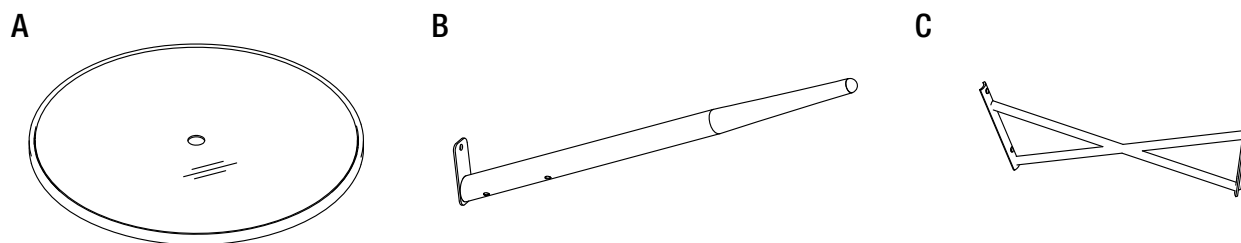

Part	Description	Quantity
A	Table Top	1
B	Legs	4
C	Leg Brace	4

Assembly

Note: Do not tighten all bolts until the last step. Please fully assemble the unit on a flat surface to level the product. Once leveled, tighten all bolts.

1 Attaching the Legs

- Place all parts on a flat, clean surface.
- Attach the Legs (B) to the Table Top (A) using the Bolts (BB), Washers (AA) and Hex Wench (CC).
- Do not fully tighten the bolts yet.

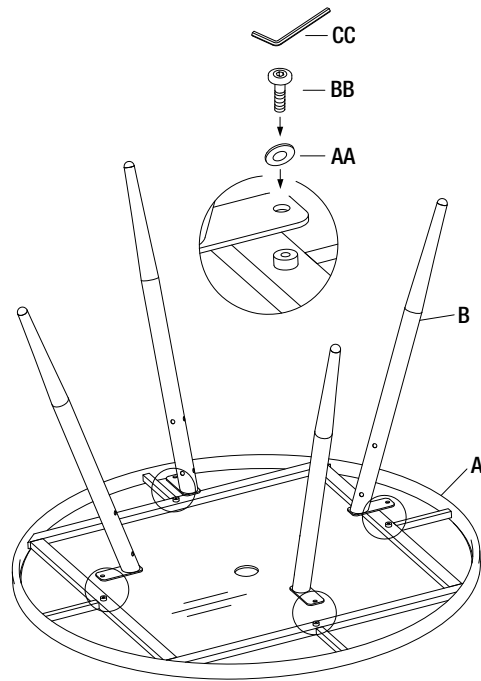

2 Attaching the Leg Brace

- Attach the Leg Brace (C) to the Legs (B) using the Bolts (BB), Washers (AA) and Hex Wench (CC).
- Fully tighten all bolts.
- Attach the Bolt Caps (DD).

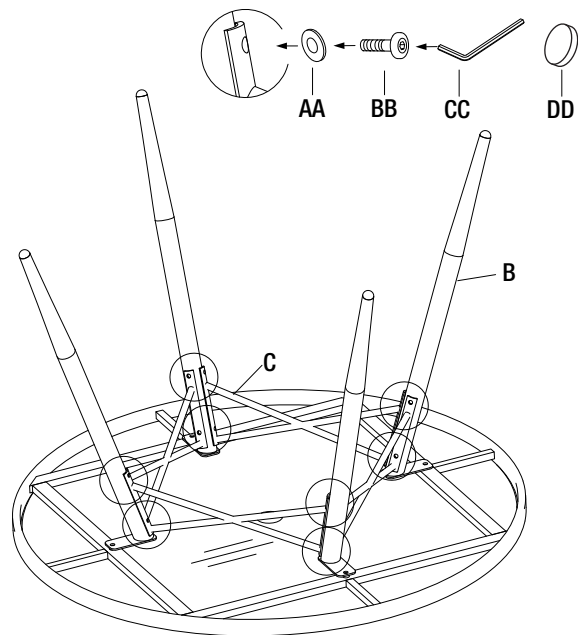

Assembly (continued)

3 Completing the Assembly

- Turn the table over and place on a flat surface.
- Attach the Umbrella Cap (EE).
- The table is now ready for use.

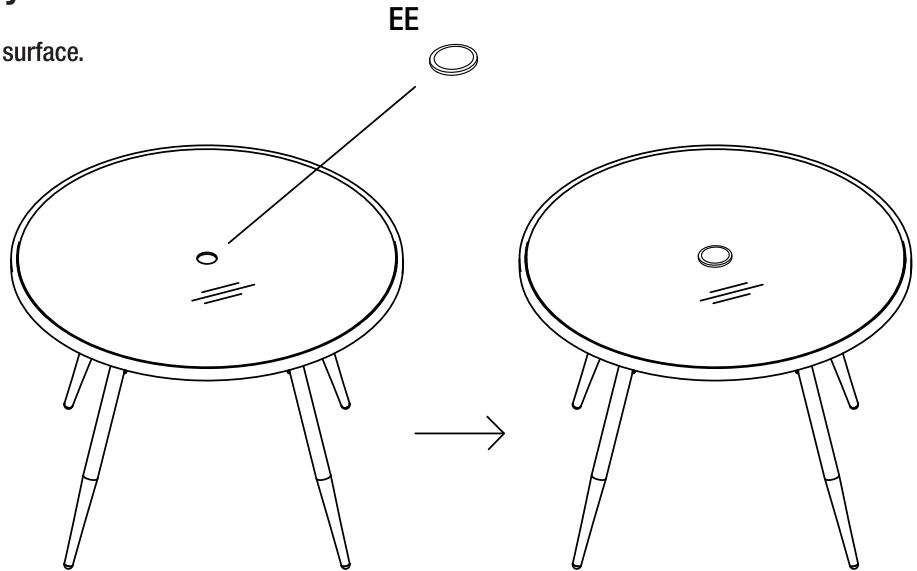



Questions, problems, missing parts? Before returning to the store,
call Hampton Bay Customer Service
8 a.m. - 7 p.m., EST, Monday – Friday, 9 a.m. – 6 p.m., EST, Saturday

1-855-HD-HAMPTON

HOMEDPOT.CA

Retain this manual for future use.